

**IMPORTANT**  
 The Contractor will be responsible for setting out the work. All dimensions must be obtained from or checked on site. Figured dimensions to be used in preference to scale.

- NOTES**
1. For speed cushions, refer to SMBC standard detail drawings SD 700-06.
  2. For speed cushion installation, every attempt should be made to AVOID any driveways, where possible.

**KEY**

② Location Number (Road Speed Cushions). Refer to table

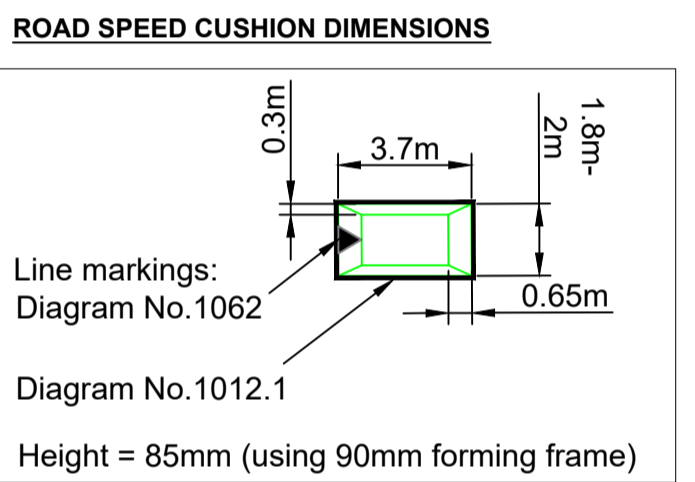

**Service Director Economy & Regeneration**  
 Tammy Stokes  
 Sandwell Council House  
 Freeth Street Oldbury  
 West Midlands B69 3DE  
 E-mail: Highways@sandwell.gov.uk

**PROJECT**  
 COMMUNITY CONCERN SCHEME – TRAFFIC CALMING

**LOCATION**  
 HARCOURT RD, CODSALL RD & TREJON RD – ROWLEY REGIS

**DRAWING TITLE**  
 GENERAL ARRANGEMENT – Sheet 3 of 5

SCALE 1:250m

ISSUED BY S.CHADWICK

DATE OCTOBER 2025

DRAWN BY JF

DRAWING No 43812 S/1

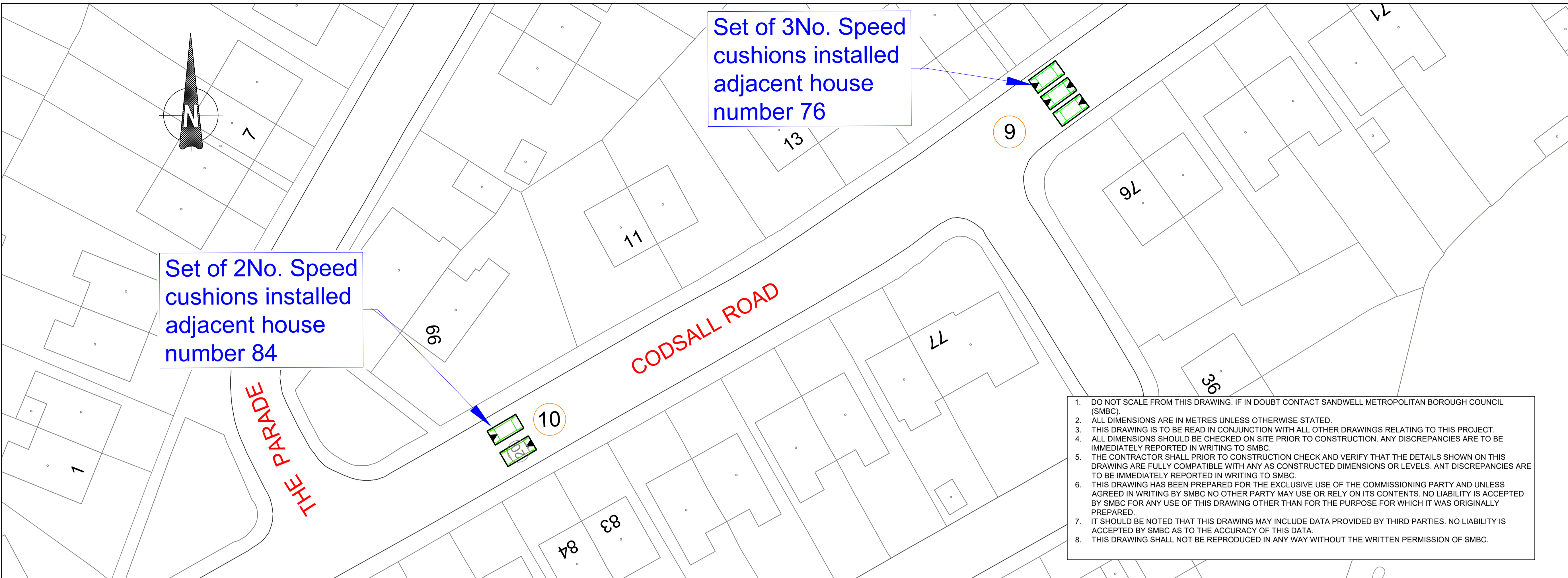

1. DO NOT SCALE FROM THIS DRAWING. IF IN DOUBT CONTACT SANDWELL METROPOLITAN BOROUGH COUNCIL (SMBC).
2. ALL DIMENSIONS ARE IN METRES UNLESS OTHERWISE STATED.
3. THIS DRAWING IS TO BE READ IN CONJUNCTION WITH ALL OTHER DRAWINGS RELATING TO THIS PROJECT.
4. ALL DIMENSIONS SHOULD BE CHECKED ON SITE PRIOR TO CONSTRUCTION. ANY DISCREPANCIES ARE TO BE IMMEDIATELY REPORTED IN WRITING TO SMBC.
5. THE CONTRACTOR SHALL PRIOR TO CONSTRUCTION CHECK AND VERIFY THAT THE DETAILS SHOWN ON THIS DRAWING ARE FULLY COMPATIBLE WITH ANY AS CONSTRUCTED DIMENSIONS OR LEVELS. ANY DISCREPANCIES ARE TO BE IMMEDIATELY REPORTED IN WRITING TO SMBC.
6. THIS DRAWING HAS BEEN PREPARED FOR THE EXCLUSIVE USE OF THE COMMISSIONING PARTY AND UNLESS AGREED IN WRITING BY SMBC NO OTHER PARTY MAY USE OR RELY ON ITS CONTENTS. NO LIABILITY IS ACCEPTED BY SMBC FOR ANY USE OF THIS DRAWING OTHER THAN FOR THE PURPOSE FOR WHICH IT WAS ORIGINALLY PREPARED.
7. IT SHOULD BE NOTED THAT THIS DRAWING MAY INCLUDE DATA PROVIDED BY THIRD PARTIES. NO LIABILITY IS ACCEPTED BY SMBC AS TO THE ACCURACY OF THIS DATA.
8. THIS DRAWING SHALL NOT BE REPRODUCED IN ANY WAY WITHOUT THE WRITTEN PERMISSION OF SMBC.

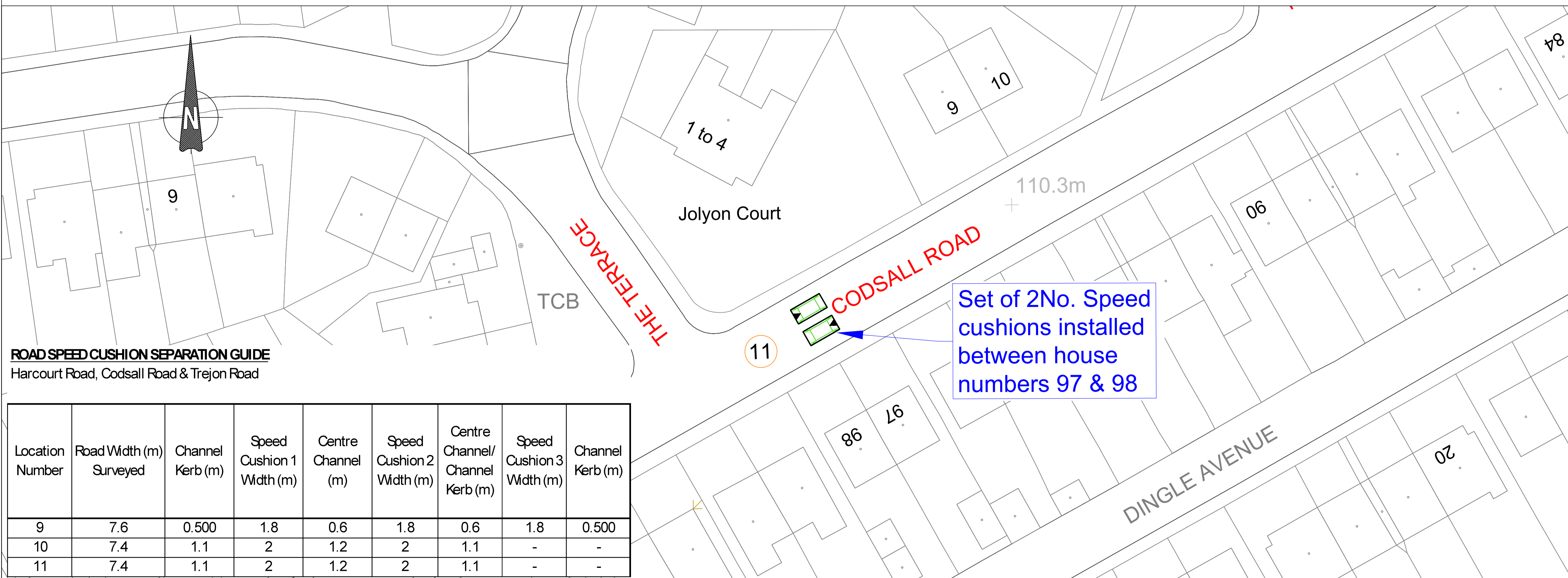

**ROAD SPEED CUSHION SEPARATION GUIDE**  
 Harcourt Road, Codsall Road & Trejon Road

Location Number	Road Width (m) Surveyed	Channel Kerb (m)	Speed Cushion 1 Width (m)	Centre Channel (m)	Speed Cushion 2 Width (m)	Centre Channel/Channel Kerb (m)	Speed Cushion 3 Width (m)	Channel Kerb (m)
9	7.6	0.500	1.8	0.6	1.8	0.6	1.8	0.500
10	7.4	1.1	2	1.2	2	1.1	-	-
11	7.4	1.1	2	1.2	2	1.1	-	-